

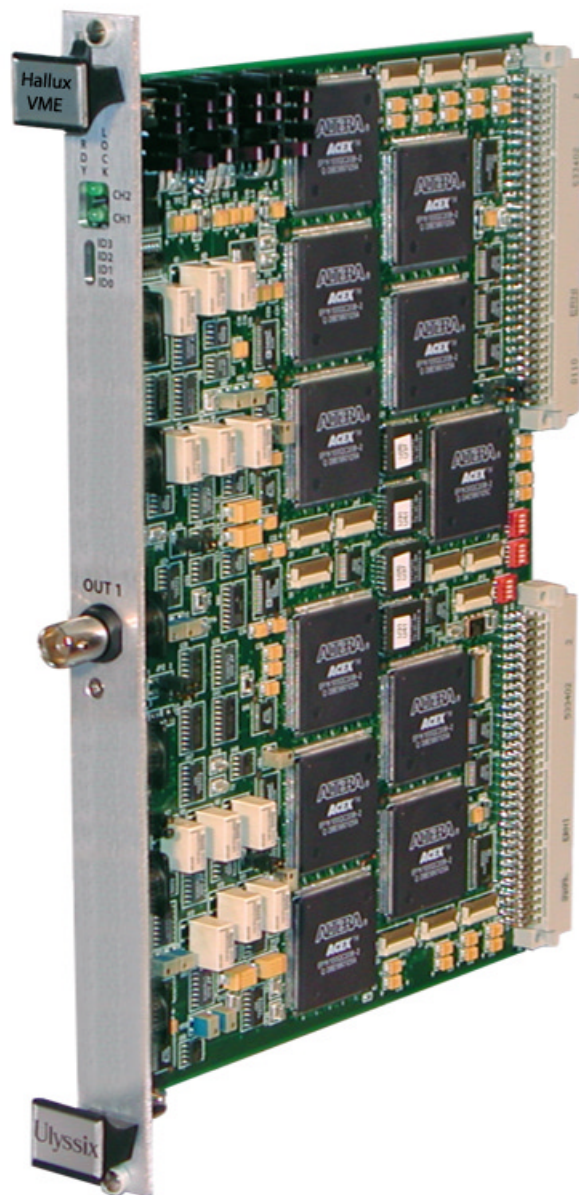

The **HallaxVME 16 Channel Digital Calibrator**, a companion product to the Ulyssix Syrnix-DualVME Dual Digital FM Demodulator, is a DSP (Digital Signal Processing) based FM calibrator card designed around the **VME** form factor. DSP algorithms are implemented in state-of-the-art FPGAs (Field Programmable Gate Arrays) allowing for rapid enhancements or customization.

The card provides up to sixteen fully programmable FM calibrator channels. Each calibrator channel is configured for frequency, deviation, and autostep profile. Fully programmable, all IRIG 106-93 CBW and PBW FM subcarriers are supported as well as non-standard frequencies with a carrier frequency range of 250 Hz to 5 MHz.

Using DSP based algorithms, including Modulated Numerically Controlled Oscillators (MNCO) with 32 bit phase accumulators, the **Hallax-DualVME** is extremely accurate and stable. C++ language source code and a detailed technical manual are supplied which aids in creating integrated instrument software for complex **VME** applications. The **HallaxVME 16 Channel Digital Calibrator** is a natural addition to any Telemetry or Satellite Communications ground station.



## FEATURES

- 6U VME form factor
- Up to sixteen (16) calibrator channels
- Fully programmable for all IRIG 106-93 FM CBW and PBW subcarriers as well as non-standard channels
- Subcarrier harmonic distortion less than -56dB
- Subcarrier frequency range of 250 Hz to 5 MHz
- Automatic and Manual calibration modes
- Modulated output level programmable from 1.0 to 10.0 Vpp
- Programmable Pre-Emphasis scheduling, if desired
- FM subcarrier deviations from 0.5% to 50% of the center frequency

# SPECIFICATIONS

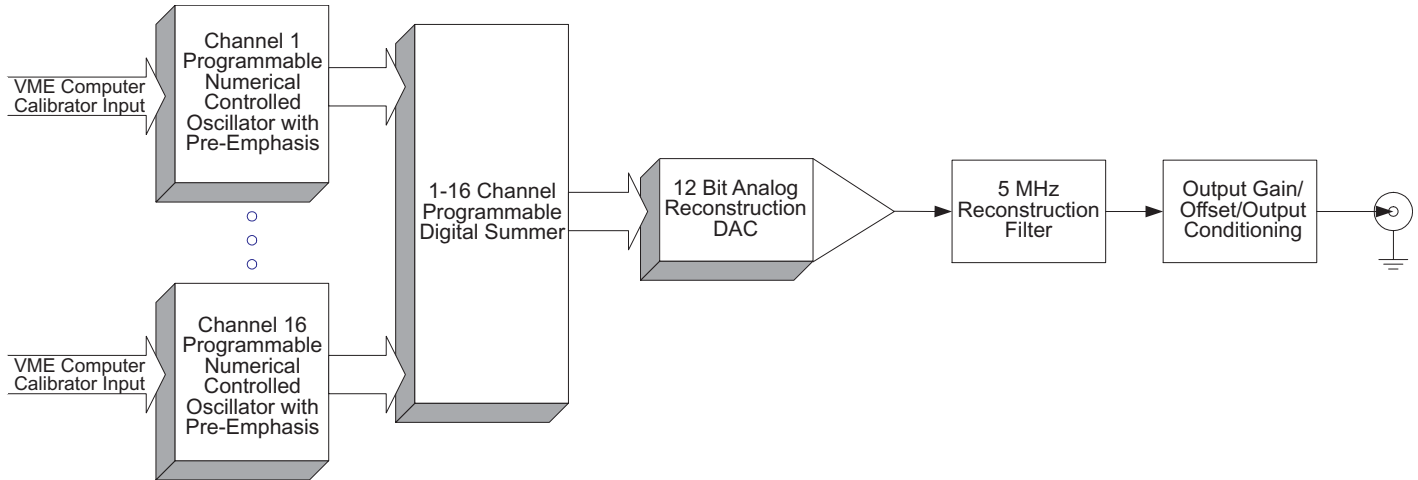

HallaxVME Block Diagram

## SPECIFICATIONS

### Calibrator Specifications

- Channels per Multiplex Sixteen (16) max
- Multiplex Output Level Programmable from 1.0 to 10.0 Vpp into a 1K Ohm load
- Frequency Range 250 Hz to 5 MHz
- Analog Output Noise Less than 10 mVRMS
- Calibration Modes Manual or Automatic (Autostep)
- Calibration Steps 3 to 21 steps from -100% to +100% deviation Selectable
- Autostep Dwell Time 0.5 to 10 seconds per step Programmable in 0.1 second increments
- Modulation Modes FM
- Center Frequency Resolution 0.0002 ppm (1 part in  $2^{32}$ )
- FM Deviation Range 0.5% to 50.0% of center frequency
- Subcarrier Harmonic Distortion All harmonic terms are below -56 dB
- Pre-emphasis Scheduling Programmable from 0 to -20 dB per subcarrier
- Deviation Accuracy 0.0244% of the programmed center frequency
- Frequency Stability 25 ppm over the full operation range

### Physical Specifications

- VME Form Factor 32 bit VME 6U form factor
- Interface Connectors Outputs - PCB mounted BNC connectors
- Manufacturing The design utilizes Surface Mount Technology (SMT), manufactured with robotic assembly techniques to IPC-610B Class 2 manufacturing standards
- Temperature Range Operating: 0°C to 50°C Storage: -20°C to 60°C
- Power Consumption: Less than 35 Watts total, for all supplies

### Ordering Information

- HalluxVME-01 Standard Calibrator Unit

*Specifications subject to change without notice.*